

PAPER • OPEN ACCESS

## Hybrid robot climbing system design

To cite this article: Agustinus Purna Irawan *et al* 2017 *IOP Conf. Ser.: Mater. Sci. Eng.* **237** 012006

### Related content

- [Robots take off!](#)
- [Industry: Robots march on](#)
- [Robots 1 Humans 0?](#)

View the [article online](#) for updates and enhancements.

## Hybrid robot climbing system design

**Agustinus Purna Irawan\***, Agus Halim and Hengky Kurniawan

Department of Mechanical Engineering, Faculty of Engineering, Universitas Tarumanagara, Jakarta, Indonesia 11440

\* agustinus@untar.ac.id

**Abstract.** This research aims to develop a climbing hybrid robot, especially to design the structure of robot that quite strong and how to build an optimal mechanism for transmitting the motor's rotation and torque to generate movement up the pole. In this research we use analytical methods using analysis software, simulation, a prototype, and robot trial. The result showed that robot could climb a pole by with maximum velocity 0.33m/s with a 20 kg load. Based on a weight diversity trial between 10 kg and 20 kg we obtained climb up load factor with value  $0.970 \pm 0.0223$  and climb down load factor with value  $0.910 \pm 0.0163$ . Displacement of the frame structure was 7.58 mm. To minimize this displacement, the gate system was used so as to optimize the gripper while gripping the pole. The von Misses stress in the roller was 48.49 MPa, with 0.12 mm of displacement. This result could be a reference for robot development in further research.

### 1. Introduction

Robots are machines which are designed to help and ease human's jobs, especially to reduce risks of accident. One concept follows and has similarities to, a robot designed to climb palm trees. This robot can climb a palm tree to take coconuts, a job normally done by humans, so it assists in human activities. In this research we will used robot which canmove around on the flat floor by using caster wheels and grip a pole by using a lever mechanism powered by a compressed air, and controlled manually by a wireless joystick controller [1]. The concept dessign was made using Computer Aided Design (CAD), specifically Autodesk Inventor 2016 Student Version, while the pnelumatic dessign component used Festo Fluid SIM V4.2p/1.67. The purpose of this research is to discuss the frame structure analysis for develop a climbing system on a hybrid robot to know if the construction is sufficiently strong and how to build an optimal mechanism so robot can climb up at a certain velocity and how the load factor affect the robot velocity climbing up.

### 2. Method and materials

Methods that we used in this research were analytical methods using analysis computer's software, simulation, a prototype, and a robot trial. The first stage before actually designing the robot was to have a brainstorming session to determine what mechanism would wark best to grip a pole, climb the pole and also the most effective method to gather accurate data. The second stage ws to figure out the paarts specifications for the robot and then to come up with a design for the robot. At all stages there was constrand evaluation of the robot's system. If a problem occured we would go back and re-evaluated the design and specifications before continuing further with the robot frame structure. The final stage was to test the robot's performance and measure and collect data for comparative analysis purposes.



## 2.1. Gripping mechanism selection

There are several possible designs for the gripping mechanism of a robot which climbs vertically. One approach considered was the vacuum suction method. Despite being a good method for ascending a flat surface, such as a wall, it would prove ineffective for our purposes because it would not be able to grip a cylindrical or conical shape object such as a pole[2]. In terms of locomotion, three alternatives were considered. The first comprised wheel-driven machines, which climb vertical structures by using the wheel motion to create upward motion[3], [4], [5], [6]. This mode of movement is very effective and is especially suited to the inspection of long structures. The second locomotion method comprised a legged climbing robot, which usually consists of four or six legs, each of them having either magnets, vacuum pumps or claws attached[7], [8]. This technique provided limited maneuverability and is better suited to rugged or dangerous environments. The final mode of movement was based on the use of arms with grippers or similar devices attached [4], [9], [10]. This provided the robot with greater versatility and range of movements. Several patents exist at present for machines that are capable of tree climbing and pruning [11], [12], [13]. These machines generally completely encircle the trunk and require many actuators and are usually quite heavy[14]. After due consideration, it was decided that we would use a self lock, wheel driven system, especially since it had been proven capable of climbing up a pole. Existing research in area indicates that the major weakness in this method was that the load that a robot could carry was rather light. Our goal was to improve on the system so that the robot could climb to a height of 2.4 m.

## 2.2. Specification of Hybrid Robot

Parts specification of the robot that we used is shown in the following Table 1.

**Table 1.** Mechanical and electrical components

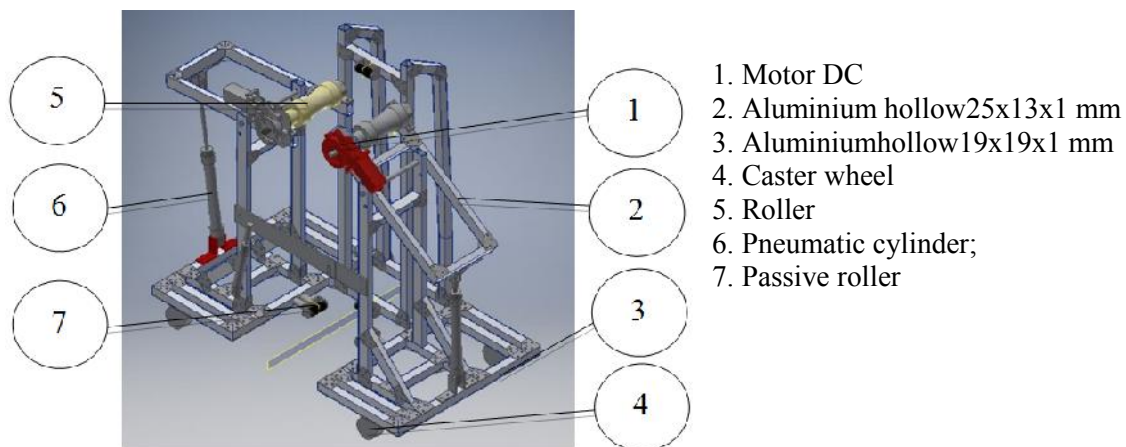
Components	Specification
Motor DC	Power window 24V, locked torque: 19.4 Nmm, torque: 5.9 Nmm
Pneumatic Cylinder	Bore diameter: 20 mm and 16 mm, stroke length: 100 mm and 45 mm
Valve	Directional Control Valve 5/2, single solenoid, spring return
Roller	Pitch diameter: 19mm, outer diameter: 50mm, total length: 125mm
Caster wheel	diameter = 50mm
Structure	Aluminium hollow profile (19x19x1mm and 25x3x1mm)
Roller shaft	diameter 10mm [5]
Bearing UP000J	shaft diameter 10mm, outer diameter 35mm, width 10mm
Microcontroller	ATMega 16
Motor Driver	L293D
Motor Driver	EMS 30A H-Bridge
Sensor	Infrared Proximity Sensor

## 3. Results and discussion

### 3.1. Hybrid Robot Design

The 3D CAD design of the robot was preceded by a discussion on the ultimate objectives we wanted the robot to obtain, the system of implementation, theoretical calculations, tools and raw materials availability (by arranging a bill of materials), arranging job shifts for the

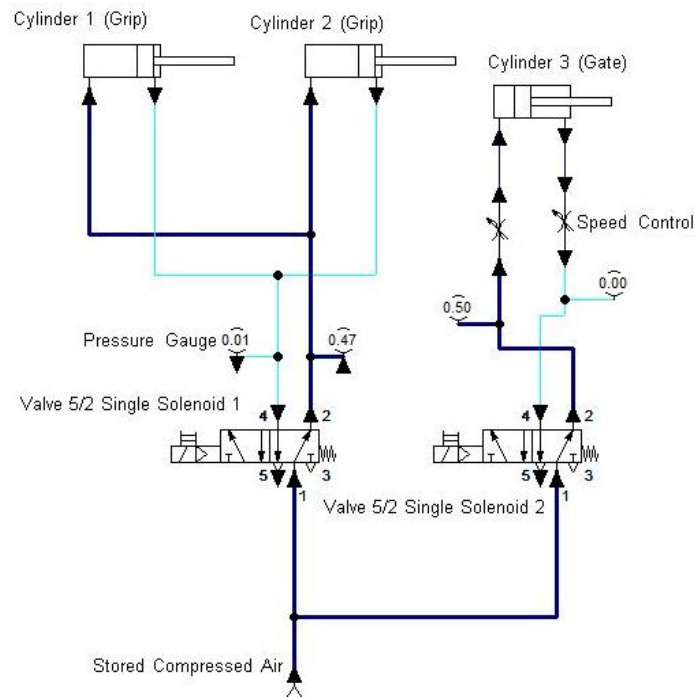
fabrication stages, and final preparations for constructing the robot. This design presents an orthogonal view of the robot, caster wheels were used prevent slipping movement of the robot on a flat floor. We used an aluminium profile for the frame because it is light and provides a solid structure for the base frame. A passive roller was put in place to keep the robot's position straight while climbing up and down. A pneumatic cylinder was placed in position (Figure 1) to generate grip in the lever mechanism. To grip the pole, the robot deploys the lever mechanism which we added to ensure that the back force created when the grippers grip the pole cause s little displacement to the frame structure as possible, and minimize any bending in the frame components.



**Figure 1.** Structural design of hybrid robot

### 3.2. Pneumatic system design on hybrid robot

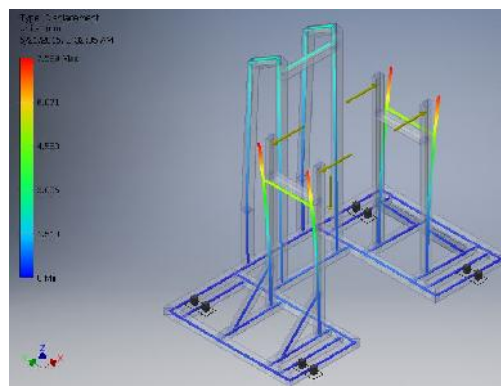
The pneumatic system design was prepared and put through simulations before we actually built the hardware to minimize the risk of errors (Figure 2). The pneumatic system on the robot uses PET bottles to store pressurized air at a maximum of 0.5 MPa. The flow of the pressurized air is controlled by a directional control valve 5/2 single solenoid spring return which works as the control valve. Under normal conditions, the pressurized air will flow directly from the valve to the cylinder and pressure gauge, so the cylinder piston rod will always be extended causing the grip system to hold firmly to the pole. In the event of a sudden loss of electrical power, this system will allow the robot to maintain its grip on the pole thus preventing the robot from falling down the pole.



**Figure 2.** Design of pneumatic system

### 3.3. The Structural strength simulation results

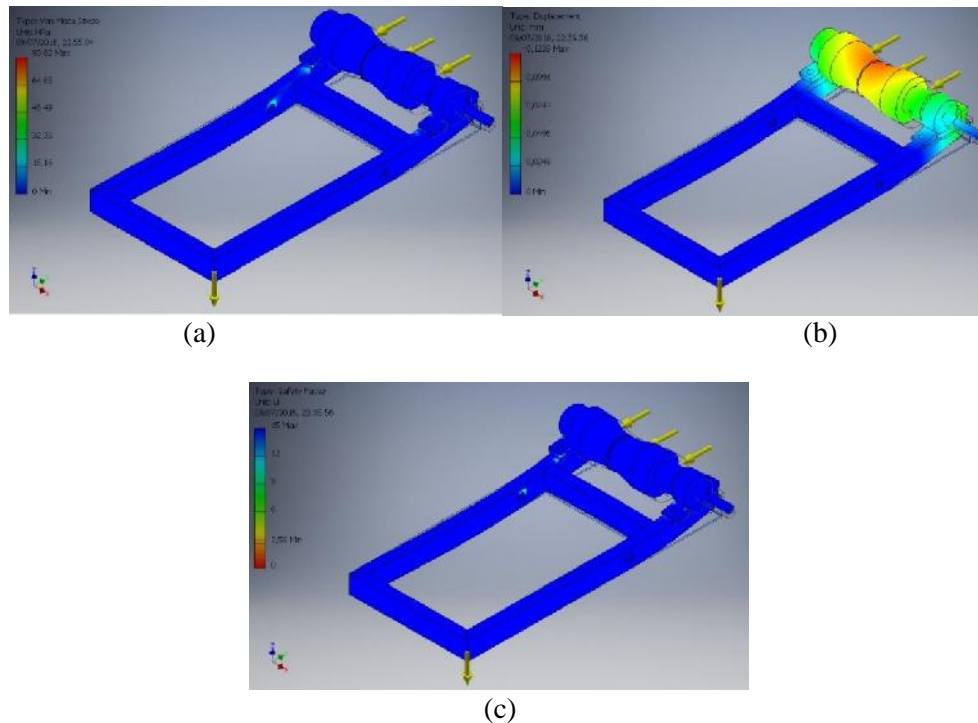
The structural analysis of the frames occurred during the contact force exerted by grip mechanism while gripping the pole and was recorded as 269 N force. By using the frame analysis a displacement of 7.58 mm was measured. This problem was remedied by adding the gate system which decreased the displacement by 4-6 mm.



**Figure 3.** Maximum displacement simulation of frame analysis

The stress analysis simulation was used in order to determine the displacement of the roller structure and the lever that exerted the contact force while gripping the pole. The force applied on the roller is a 269 N bearing load, so the values obtained from the simulation are 48.49 MPa of Von Mises stress, 0.12 mm of displacement, and 15 of maximum safety factor value as well as 9 of minimum safety factor value. Safety factor needed to ensure the safety of the robot in lifting weights. The design of the structure must provide a safety factor that is

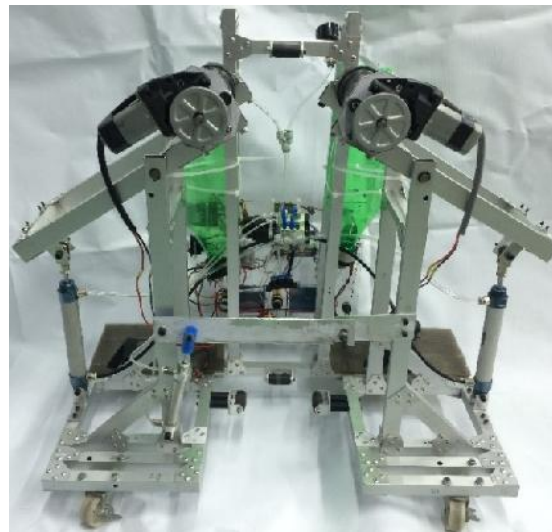
adequate in accordance with the working conditions it receives. The value of the safety factor depends on the working conditions of the product being designed [15] [16].



**Figure 4.** Von Mises stress simulation (a), maximum displacement simulation (b), safety factor simulation (c)

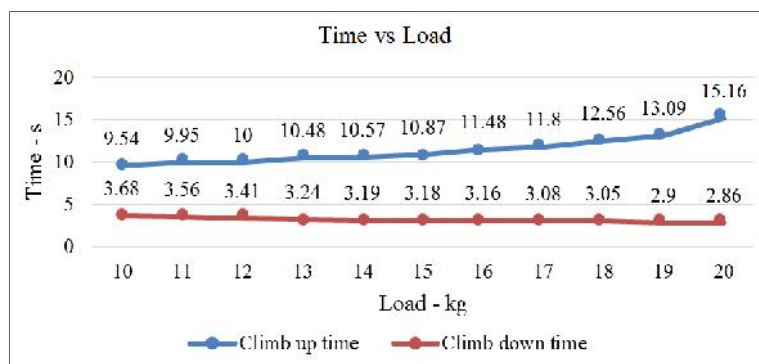
### 3.4. Implementation, evaluation, and test result

The implementation result was done based on a 3D CAD design and pneumatic system. Each of the joints of the robot was linked with a riveted joint system, which is used since it is easy to implement, and strong enough to support the structure with a maximum weight limit of 25 kg. The total weight of the robot with supporting equipment such as Li-Po battery was 10 kg (Figure 5). Li-Po battery usage refers to the Omni Climber hybrid robot designed by Tavakoli et al where the robot is operated by a 1000 mAh Li-Po battery [17]. Maximum climbing speed of robot is 0.33 m/s with a total weight of 20 kg. If compare with the Omni Climber hybrid robot (maximum climbing speed is 0.14 m/s), this robot has climbing speed faster [17]. To ensure robot stability while working at altitudes and to safely descend the pole, further research should focus on the influence of elevated wind loads. Safety should be considered for robots to work at altitudes with different wind loads [18]. The stability of the robot when climbing is determined by the gripper design. The robot should not climb by swaying, but must be gripped perfectly between the gripper and the pole surface [19].

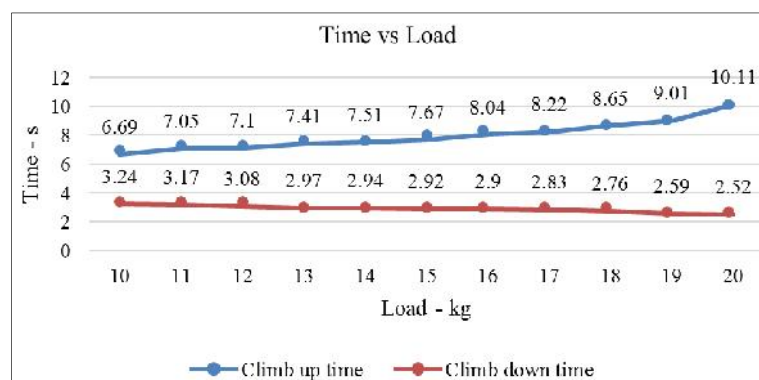


**Figure 5.** Result of the implementation of the hybrid robot

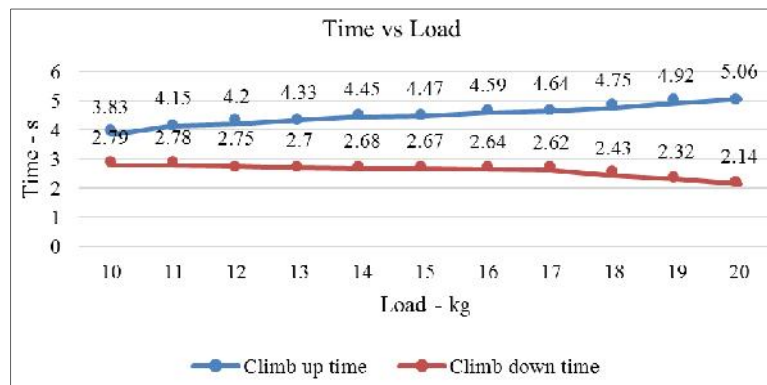
At the evaluation stage, the robot was tested to climb the pole. A load was placed on each left and right side of the robot giving the robot close to maximum weight conditions, which is 20 kg. Result showed that the robot was able to climb the pole without any defects in the frames detected. With a load applied, the robot is tested to climb the pole at various climbing velocities. The result of the tests are shown in the following Figure 6, Figure 7 and Figure 8.



**Figure 6.** The relation between time and loads with various loads added at the rate of 147.2r/min



**Figure 7.** The relation between time and loads with various loads added at the rate of 173.6r/min



**Figure 8.** The relation between time and loads with various loads added at the rate of 195 r/min

After collecting the data, the values of the loading factors are shown as follows Table 2 and Table 3.

**Table 2.** The average loading factor

Rotation (r/min)	Loading Factor	
	Increase	Decrease
147.2	$0.978 \pm 0.0323$	$0.972 \pm 0.0208$
173.6	$0.973 \pm 0.0267$	$0.973 \pm 0.0127$
195	$0.959 \pm 0.0170$	$0.950 \pm 0.0153$
Average	$0.970 \pm 0.0223$	$0.910 \pm 0.0163$

#### 4. Conclusion

The hybrid robot is able to climb up and climb down the pole with a total weight of 20 kg to a height of 2.4m. The motor used to climb the pole had enough torque to lift the robot with a maximum velocity of 0.33m/s. The greatest displacement of the frame structure was 7.59 mm. In order to minimize this displacement, the gate system was used so as to optimize the gripper while gripping the pole. The von Misses stress in the roller was 48.49MPa, with 0.12mm of displacement, and 15 of maximum safety factor value as well as 9 of minimum safety factor value. The result test shows that the value of the loading factor when the load was increased is  $0.97 \pm 0.0223$  and  $0.91 \pm 0.0163$  when the load was decreased. This result could be a reference for hybrid robot development in further research.

#### 5. Acknowledgements

The authors would like to be obliged to Universitas Tarumanagara for providing laboratory facilities and financial assistance.

#### 6. References

- [1] Xu, F.Y., Jingjin, S. and Guo Ping, J. G. 2015 *International Journal of Advanced Robotic Systems* **12-99** 1
- [2] Yoon, Y. and Rus, D. 2007 *IEEE International Conference on Robotics and Automation*, vol 1 pp. 181.
- [3] Tavakoli, M., Marques, L., and Almeida, A. T. 2010 *Industrial Robot: An International Journal* **37-3** 309
- [4] Xu, F. Y., and Wang, X. S. 2011 *Journal of Field Robotics* **28-3** 441.
- [5] Sadeghi, A., Moradi, H. and Ahmadabadi, M. N. 2012 *Journal of Robotica* **30-2** 279.



- [6] Baghani, A., Ahmadabadi, M. N. and Harati, A. 2005 *Proceedings of the 2005 IEEE International Conference on Robotics and Automation* vol. 1 pp. 2099-2104.
- [7] Haynes, G. C., Khripin, A., Lynch, G., Amory, J., Saunders, A., Rizzi, A. A. and Koditschek, D. E. 2009 *Proceedings of the IEEE International Conference on Robotics and Automation* vol 1 pp. 2767–2772.
- [8] Xu, F. Y., Wang, X. S. and Jiang, G. P. 2012 *International Journal of Advanced Robotic Systems* **9**-1-12.
- [9] Lam, T. L. and Xu, Y. S. 2012 *Journal of Field Robotics* **29-6** 843
- [10] Tavakoli, M., Marjovi, A. and Marques, L. 2008 *Proceedings of the IEEE/RSJ International Conference on Intelligent Robots and Systems* vol. 1 pp. 4130-4135.
- [11] Emery, W. and Shuff, H. 1949 *Patent US2477922*.
- [12] Whitaker, R. 1949 *Patent US2482392*.
- [13] Grasham, C. 1952 *Patent US 2581479*.
- [14] Fauroux, J. C. 2010 *Industrial Robot: An International Journal* **37**, 287-292.
- [15] Irawan, A.P., Fediyanto, Tandis, S. 2006 *Proceedings of Ergo Future* vol. 1 pp. 337-341.
- [16] Irawan, A.P., Daywin, F.J., Fanando, Agustino, T. 2016 *International Journal of Engineering and Technology* **8-3** 1543
- [17] Tavakoli, M., Lourenço, J., Viegas, C., Neto, P., Almeida, A.T. 2016 *Journal of Mechatronics* **36**, 136-146.
- [18] Xu, F.Y., Wang, X.S., Wang, L., 2011 *Transactions of the Canadian Society for Mechanical Engineering* **35-2** 269
- [19] Hariskrishna, T.V., Harshavardhan, P.D. P. R., Pandey V., 2014, *International Journal of Current Engineering and Technology* **3**, 85-88.